

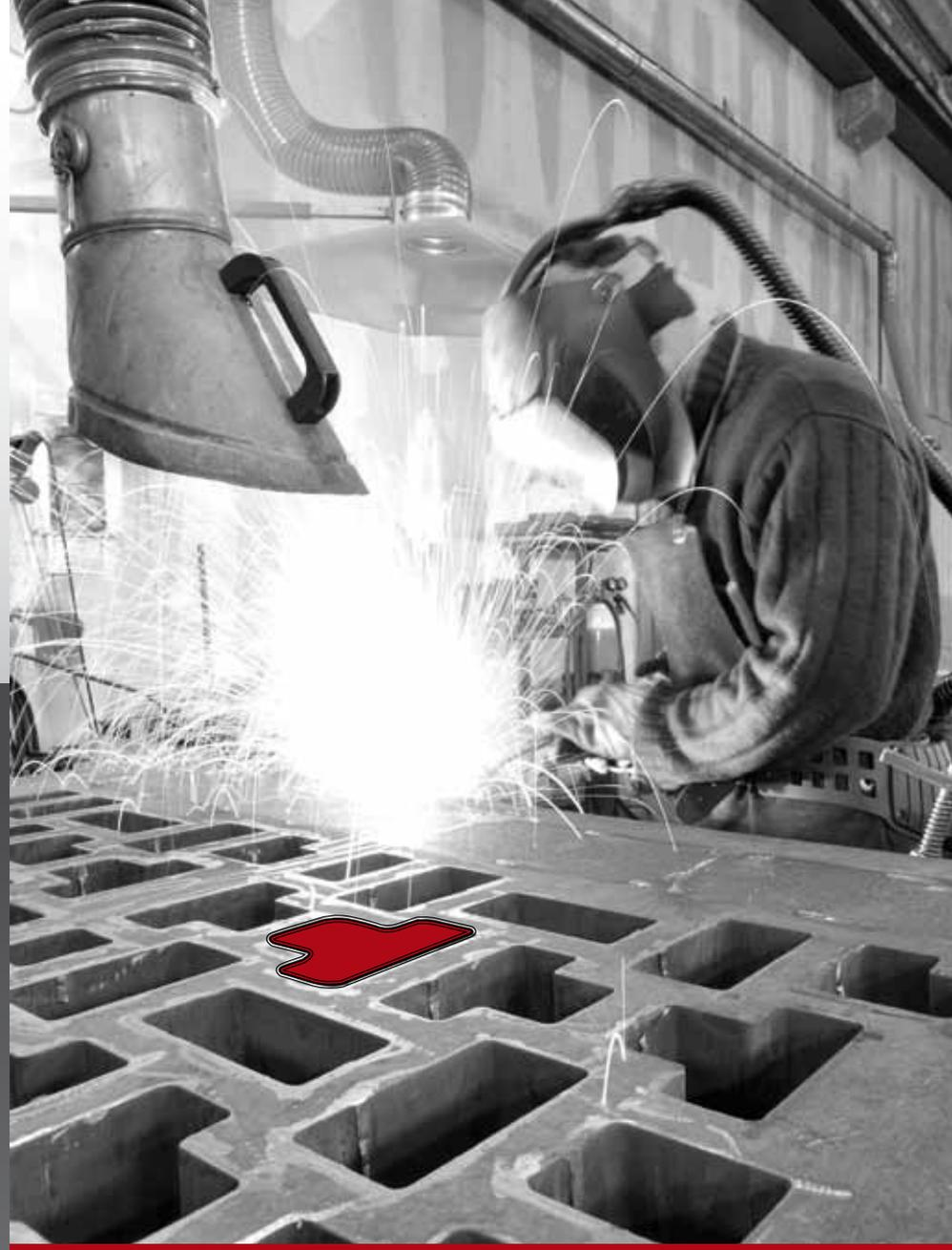

**PEGASO  
STAMPI**



**DESIGN AND  
PRODUCTION  
OF MOULDS  
FOR CONCRETE  
ELEMENTS**

# DESIGN AND PRODUCTION OF MOULDS FOR CONCRETE ELEMENTS

## PEGASO STAMPI

stampi per pavé, stampi per blocchi e cordoli,  
stampi per grigliati

Dopo più di 12 anni di attività, Pegaso Stampi si è affermata come solida realtà italiana nel campo degli stampi per elementi in calcestruzzo.

Sfruttando l'inventiva e la creatività tipicamente italiana, Pegaso Stampi è orgogliosa della propria produzione, del proprio servizio pre e post vendita e dei rapporti di collaborazione che intrattiene con i propri clienti.

## PEGASO STAMPI

moulds for paving stones, moulds for blocks and kerbs,  
moulds for garden elements

After over 12 years in the business, Pegaso Stampi has established itself as a solid Italian company in the production of moulds for concrete elements.

By exploiting typical Italian inventiveness and creativity, Pegaso Stampi is proud of its production, sales and after-sales service and of the commercial relations it maintains with its customers.

## PEGASO STAMPI

moules pour pavés, moules pour parpaings et bordures,  
moules pour grillages

« Pegaso Stampi » s'est affirmée, après plus de 12 années d'activité, comme une société italienne solide dans le secteur des moules pour éléments en béton.

Tirant profit de l'esprit d'invention et de la créativité typiquement italienne, Pegaso Stampi est fière de sa production, de son service pré/après-vente et des rapports de coopération qu'elle entretient avec ses clients.

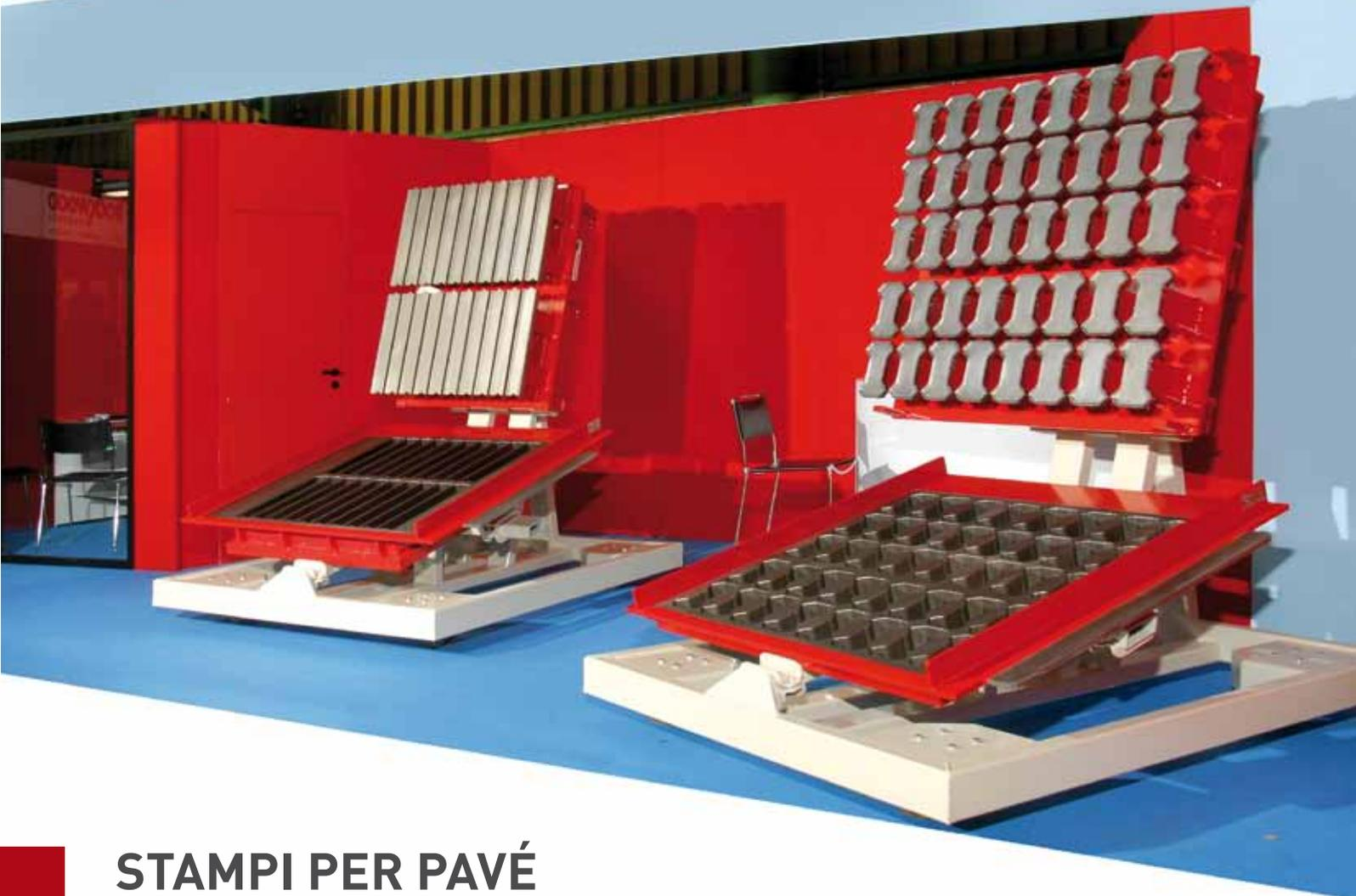

## **STAMPI PER PAVÉ**

Moulds for paving stones  
Moules pour pavés

## **STAMPI PER BLOCCHI E CORDOLI**

Moulds for blocks and kerbs  
Moules pour parpaings et bordures

## **STAMPI PER GRIGLIATI**

Moulds for garden elements  
Moules pour grillages

## **STAMPI CON ANIME SMONTABILI**

Moulds with detachable cores  
Moules à âmes démontables

## **STAMPI COMPLETAMENTE SMONTABILI**

Completely detachable moulds  
Moules entièrement démontables

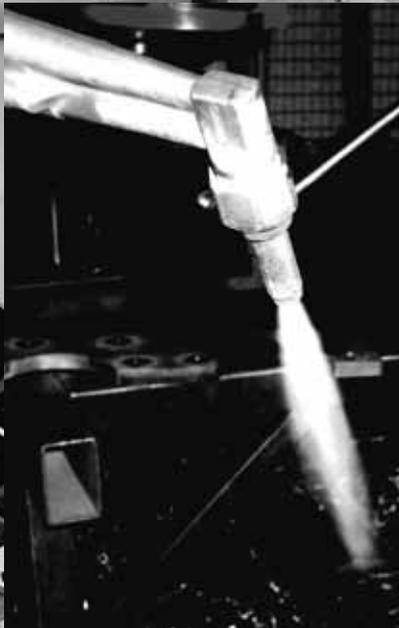
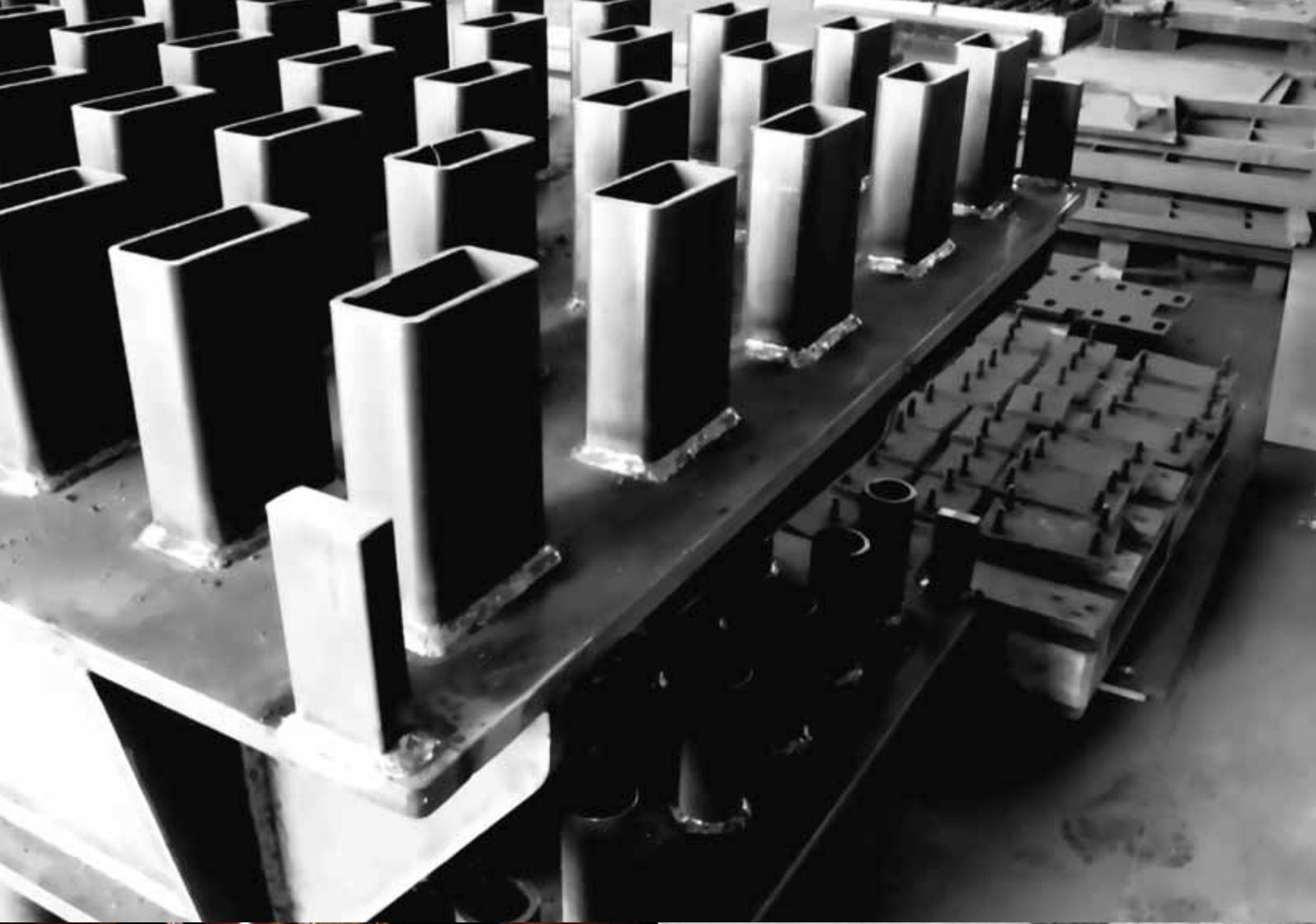



**PEGASO  
STAMPI**



# Stampi per pavé

Costruiti in acciaio altoresistenziale con forte indurimento delle superfici di lavoro, garantiscono elevatissima durata.

La precisione del taglio della cassa stampo e l'aggiustamento automatico di ogni scarpetta su ogni sagoma, assicurano un gioco costante e predefinito tra tutti i pressatori e la cassa.

Le scarpette sono lavorate di macchina utensile dal pieno con profilo coniugato alla cassa, poi vengono trattate termicamente e numerate una ad una per una precisione di alto livello.



## Moulds for paving stones

Made up of high tensile steel with high-hardened working surfaces, they assure a very long time of use. Cutting accuracy of the mould case and automatic adjustment of every single presser on each form, assure a constant and predefined clearance among all the pressers and the mould case.

The pressers are machined from the solid with the form united with the case, and then heat-treated and numbered one by one for a high accuracy level.

## Moules pour pavés

Construits en acier à haute résistance avec des surfaces de travail à fort durcissement, ils garantissent une très longue durée d'utilisation.

La précision de coupe de la boîte moule et l'ajustage automatique de chaque presseur sur chaque forme, garantissent un jeu constant et prédéfini entre tous les presseurs et la boîte moule.

Les presseurs sont usinés dans la masse avec le profil conjugué à la boîte, puis ils sont soumis à un traitement thermique et ils sont numérotés un par un pour une précision au niveau le plus élevé.



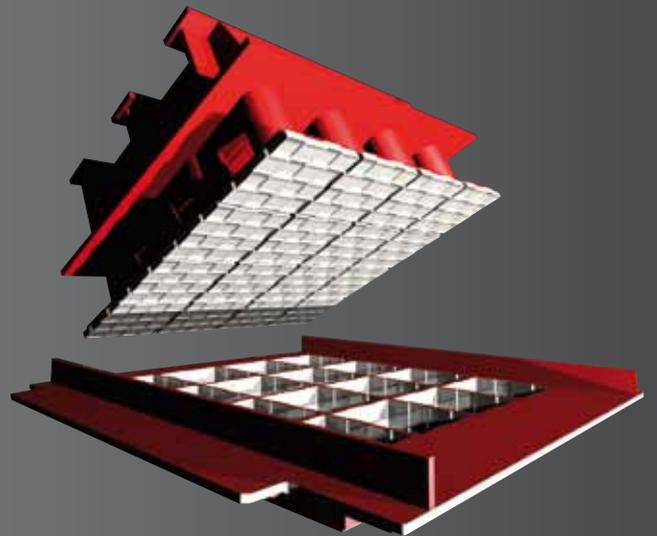
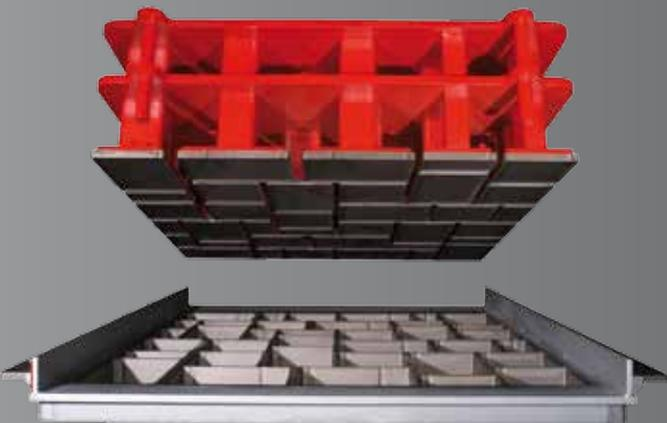
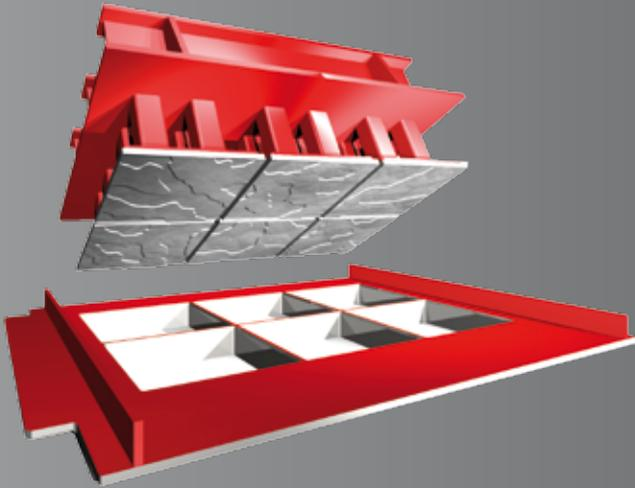
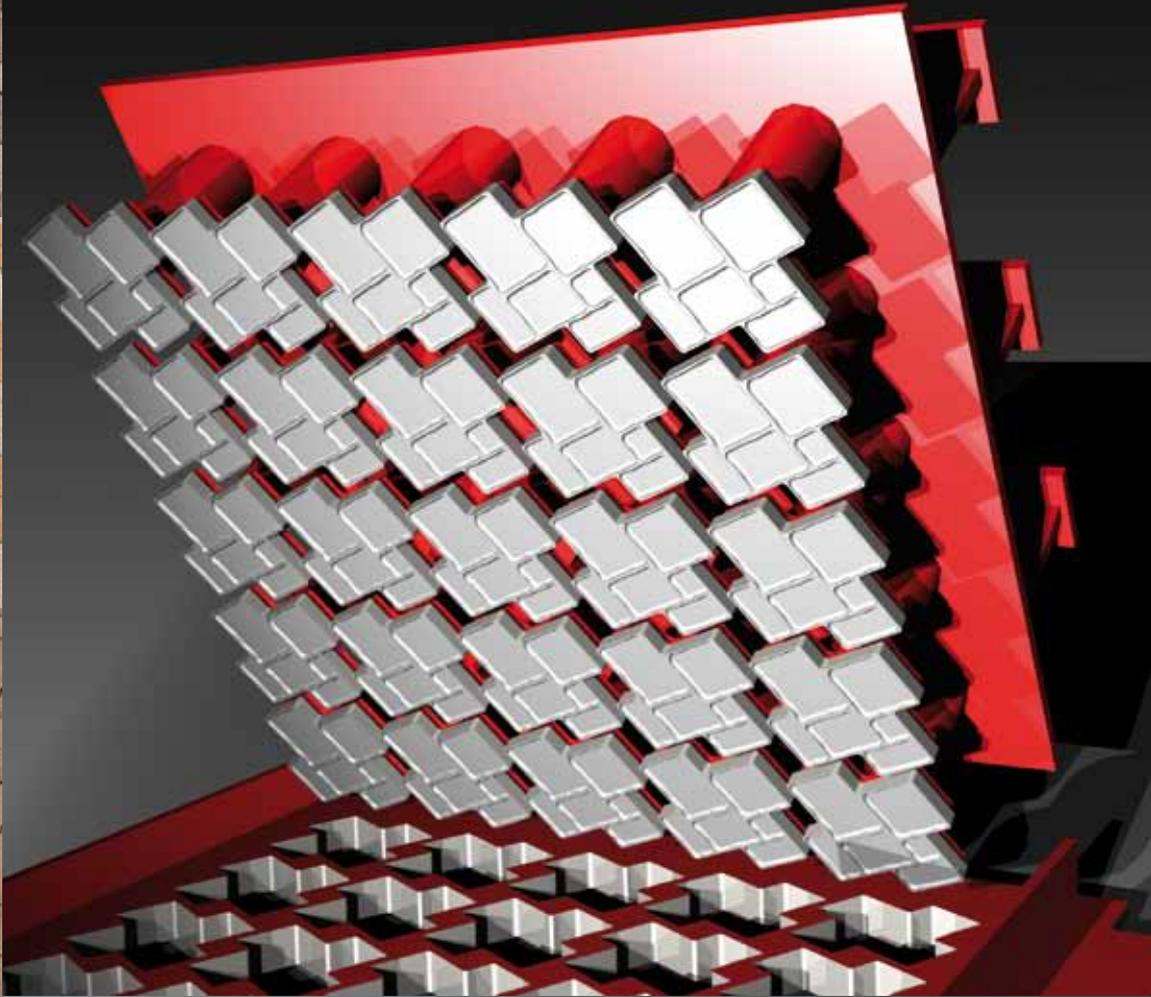



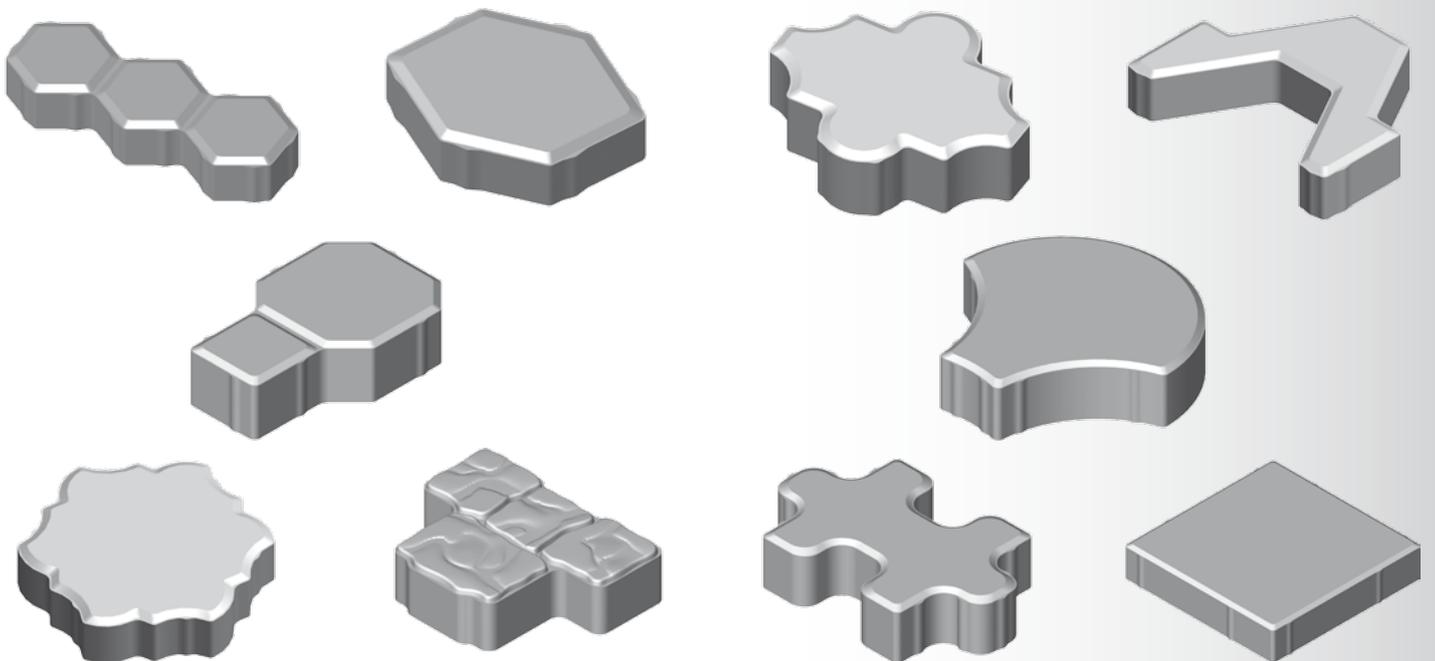
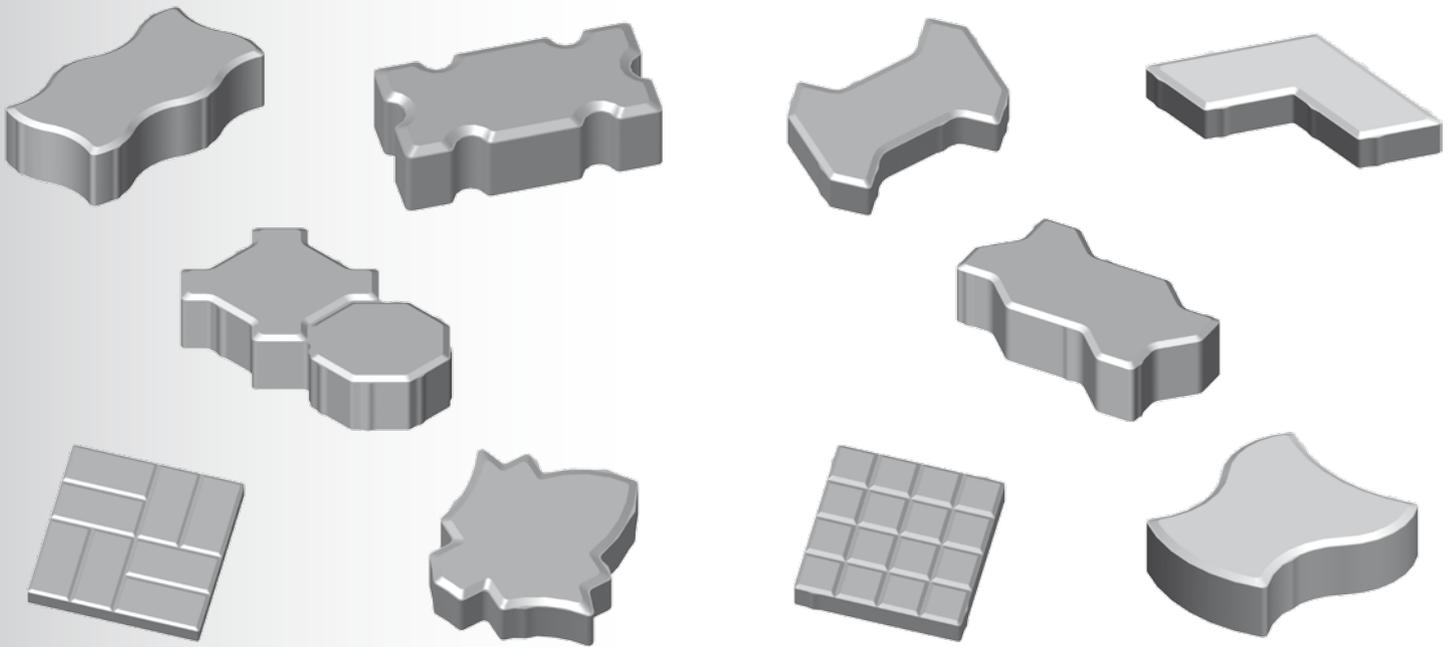
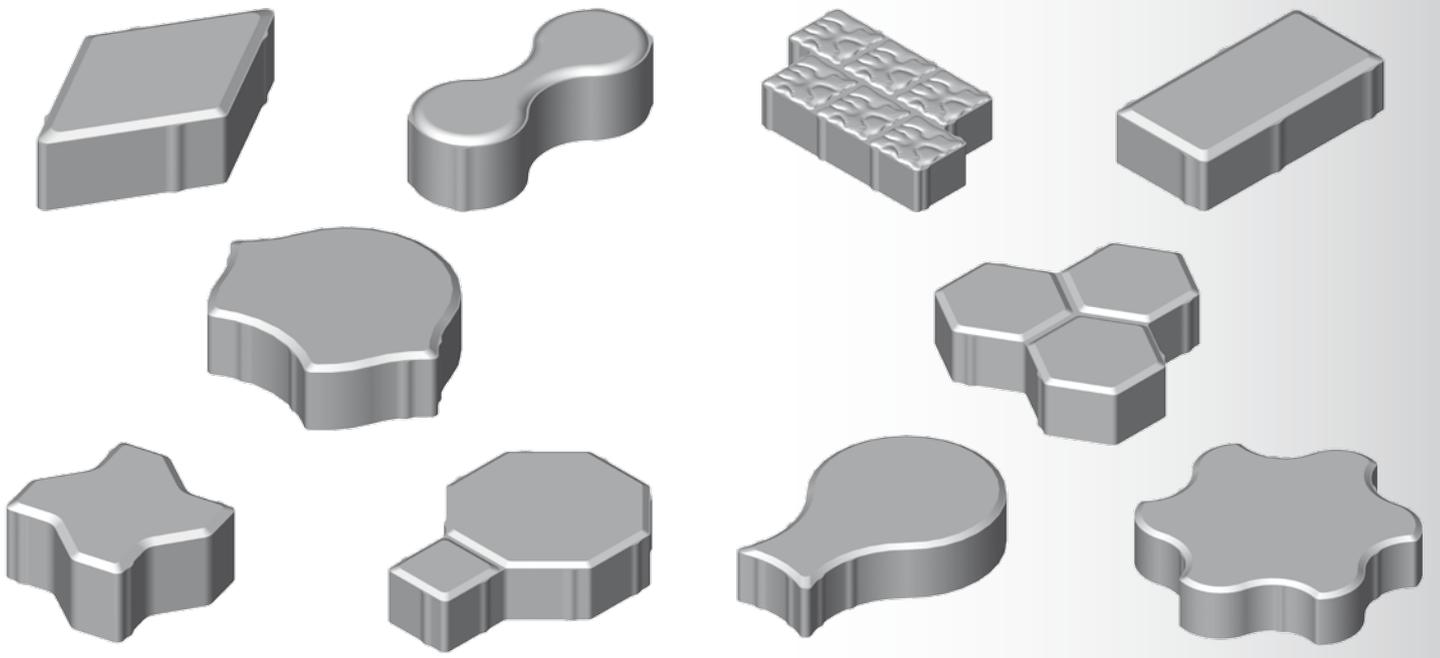

# Stampi per blocchi e cordoli

Costruiti in acciaio speciale antiabrasione sezionato al laser con dispositivi di assemblaggio innovativi, sono prodotti "fatti a mano" da specialisti di grande esperienza.

Il continuo studio sui materiali e sulle metodologie di assemblaggio consentono risultati di robustezza e precisione ai vertici dello stato dell'arte.

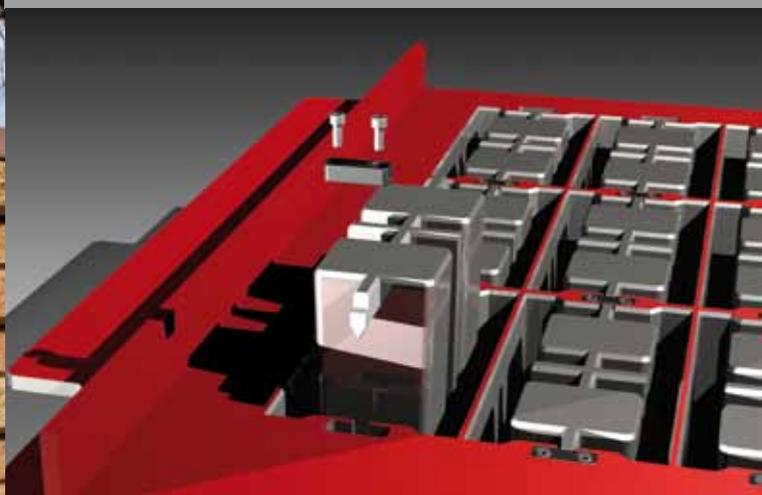

## Moulds for blocks and kerbs

Made of special abrasion-resistant laser-sectioned steel, the moulds, featuring innovative assembly devices, are "hand-made" by experienced specialists.

Endless research on materials and assembly methods provide sturdiness and accuracy results at the top of the state-of-the-art technology.

## Moules pour parpaings et bordures

Construits en acier anti-abrasion spécial découpé au laser avec des dispositifs d'assemblage novateurs, ce sont des produits "faits à la main" par des spécialistes de grande expérience. Les études continues sur les matériaux et sur les méthodologies d'assemblage permettent des résultats de solidité et de précision au sommet de l'état de la technique.



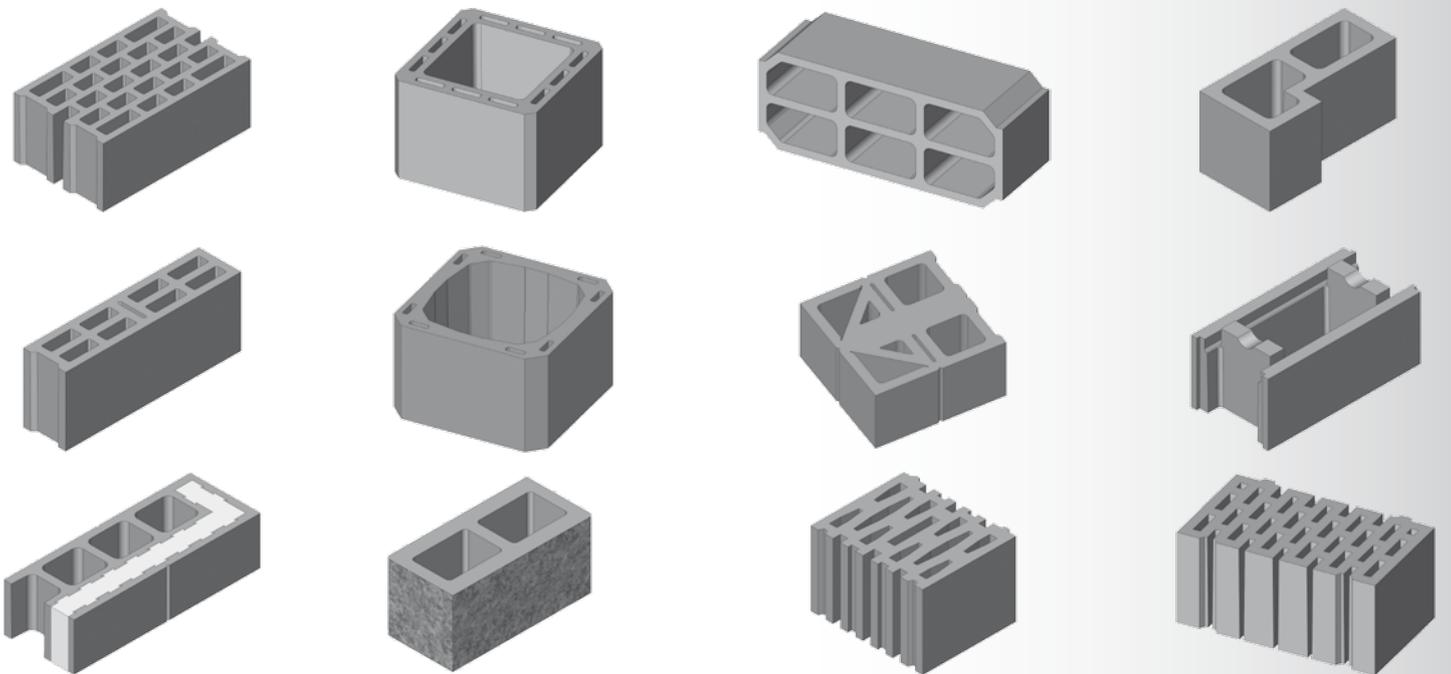
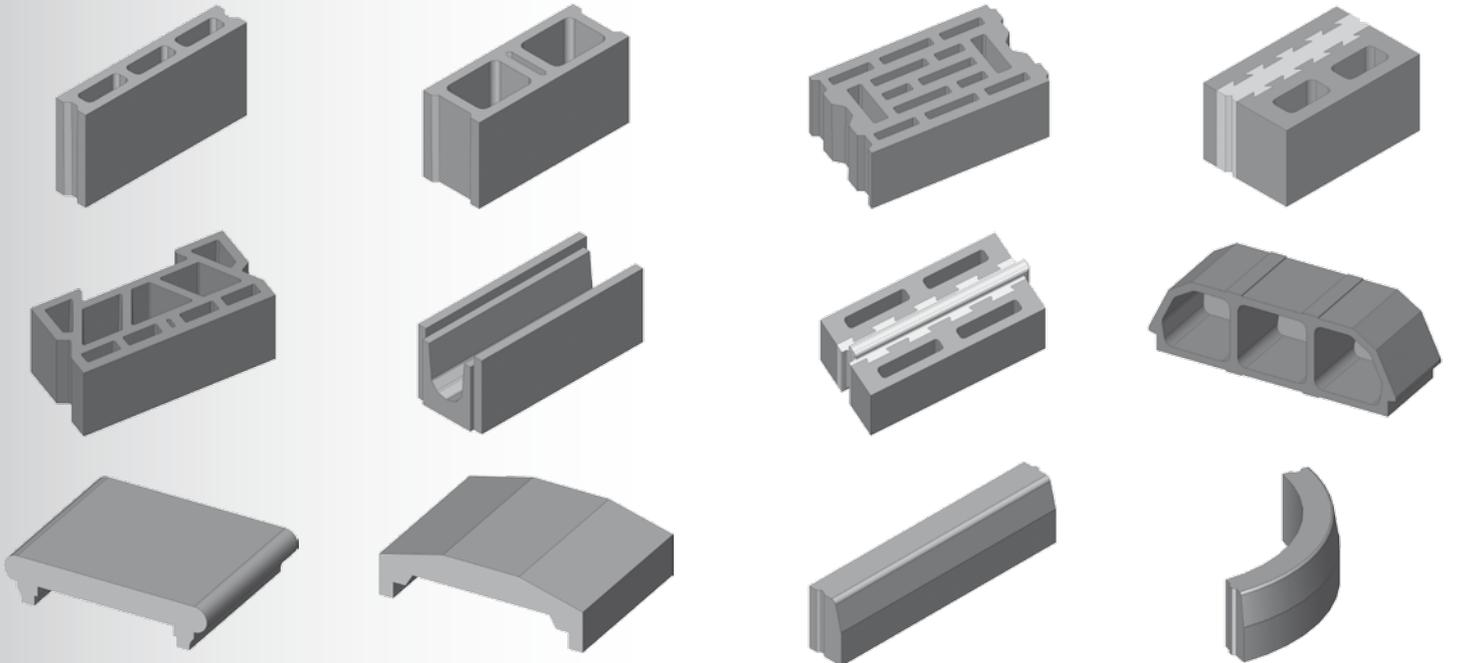

# Stampi per grigliati

Costruiti in acciaio altoresistenziale con forte indurimento delle superfici di lavoro, garantiscono elevatissima durata.

La precisione del taglio della cassa stampo e l'aggiustamento automatico di ogni scarpetta su ogni sagoma, assicurano un gioco costante e predefinito tra tutti i pressatori e la cassa.

Le scarpette sono lavorate di macchina utensile dal pieno con profilo coniugato alla cassa, poi vengono trattate termicamente e numerate una ad una per una precisione di alto livello.

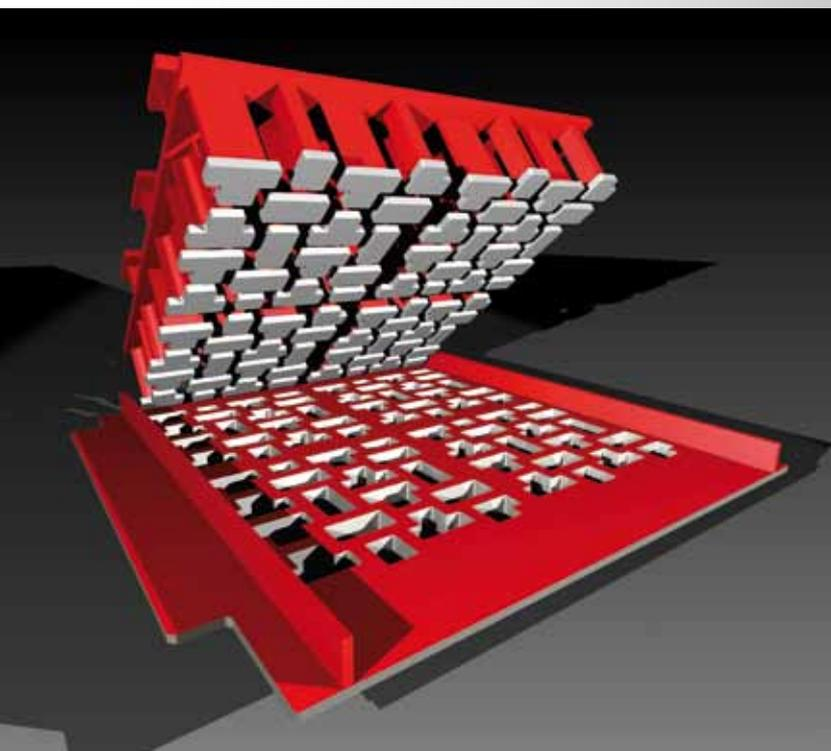

# Moules pour grillages

Construits en acier à haute résistance avec des surfaces de travail à fort durcissement, ils garantissent une très longue durée d'utilisation.

La précision de coupe de la boîte moule et l'ajustage automatique de chaque presseur sur chaque forme, garantissent un jeu constant et prédéfini entre tous les presseurs et la boîte moule.

Les presseurs sont usinés dans la masse avec le profil conjugué à la boîte, puis ils sont soumis à un traitement thermique et ils sont numérotés un par un pour une précision au niveau le plus élevé.



## Moulds for garden elements

Made up of high tensile steel with high-hardened working surfaces, they assure a very long time of use. Cutting accuracy of the mould case and automatic adjustment of every single presser on each form, assure a constant and predefined clearance among all the pressers and the mould case.

The pressers are machined from the solid with the form united with the case, and then heat-treated and numbered one by one for a high accuracy level.



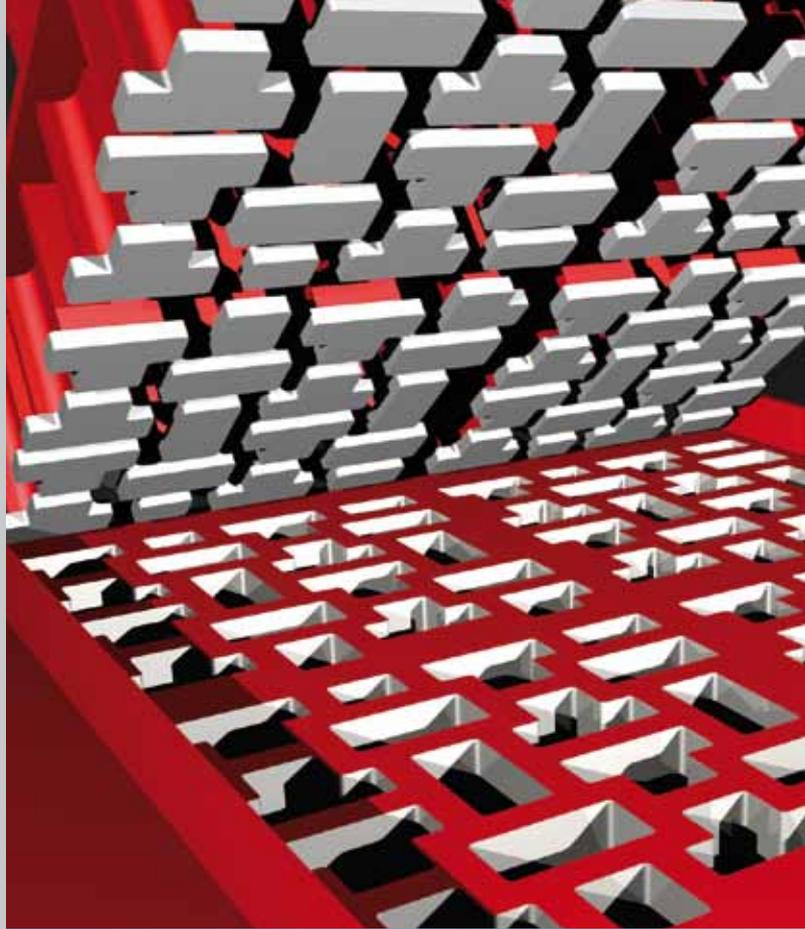
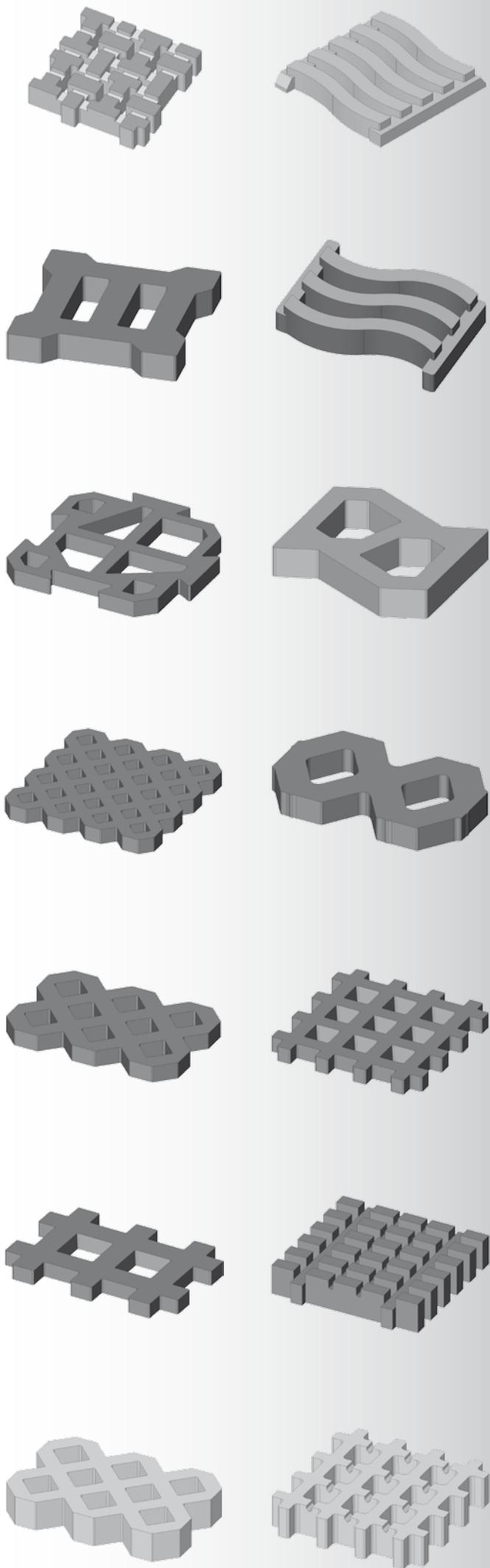

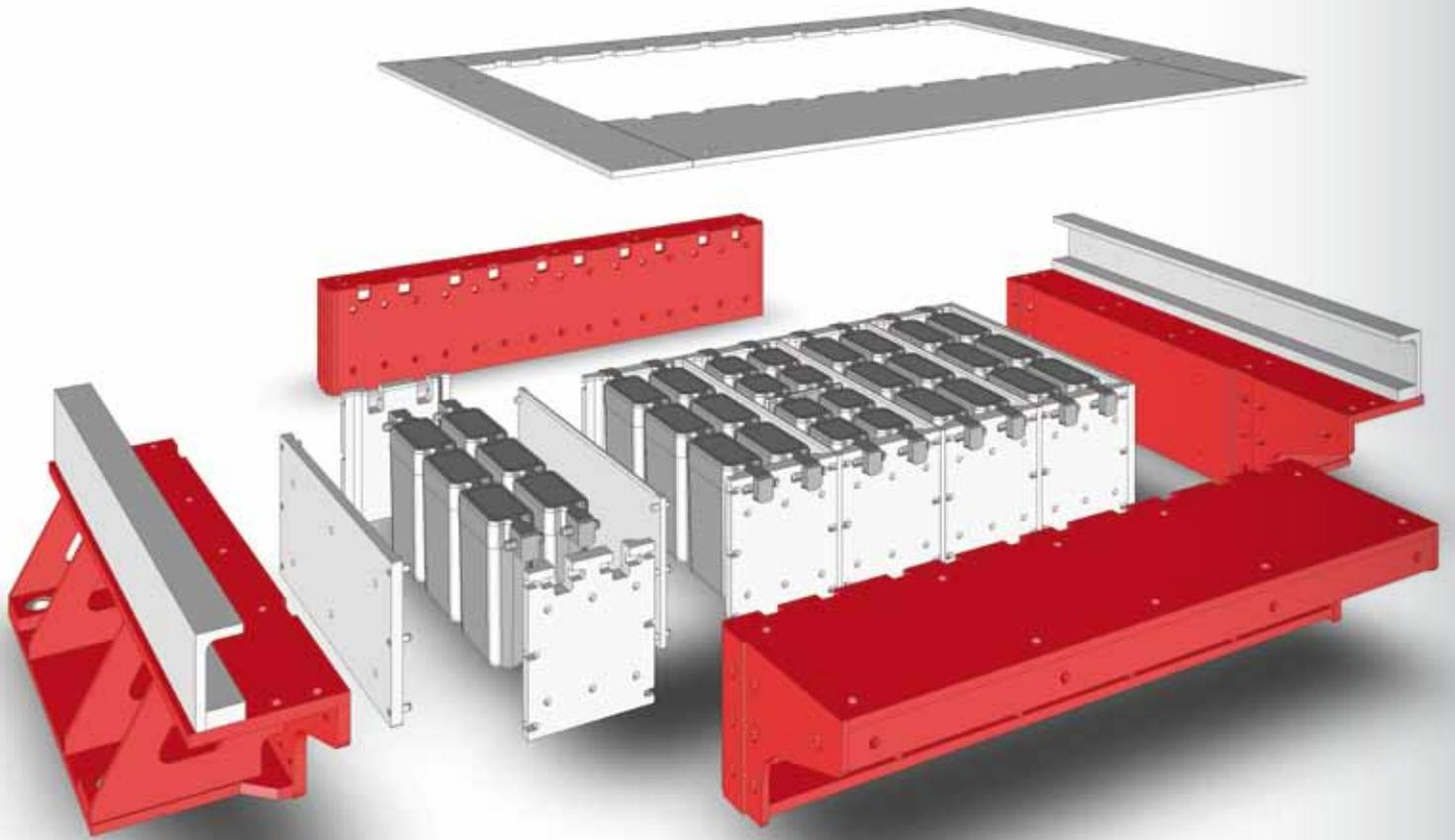

Stampi completamente smontabili

Completely detachable moulds

Moules entièrement démontables

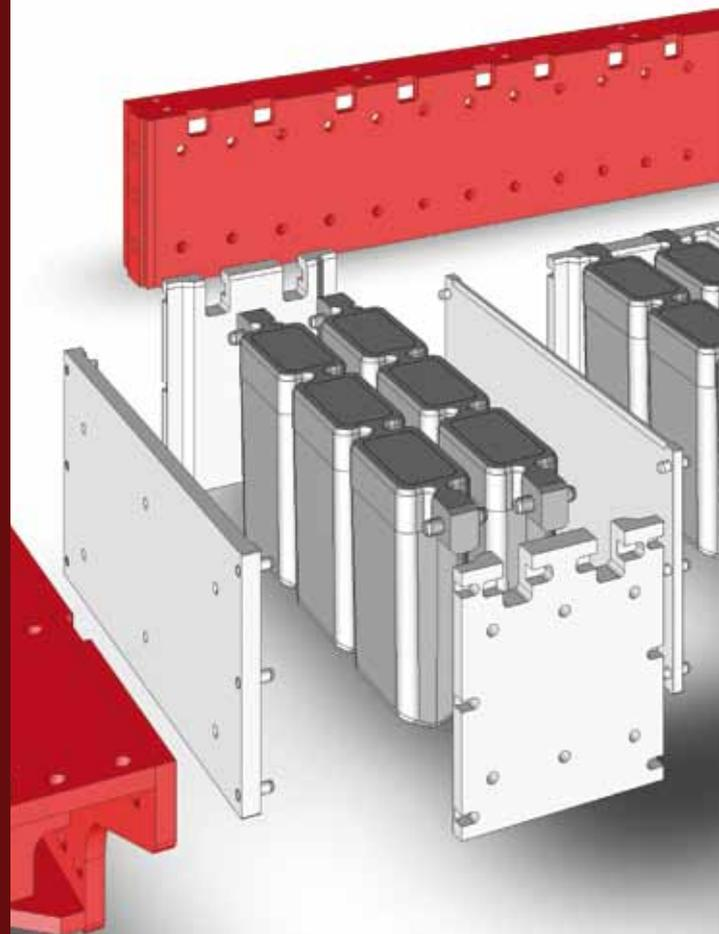

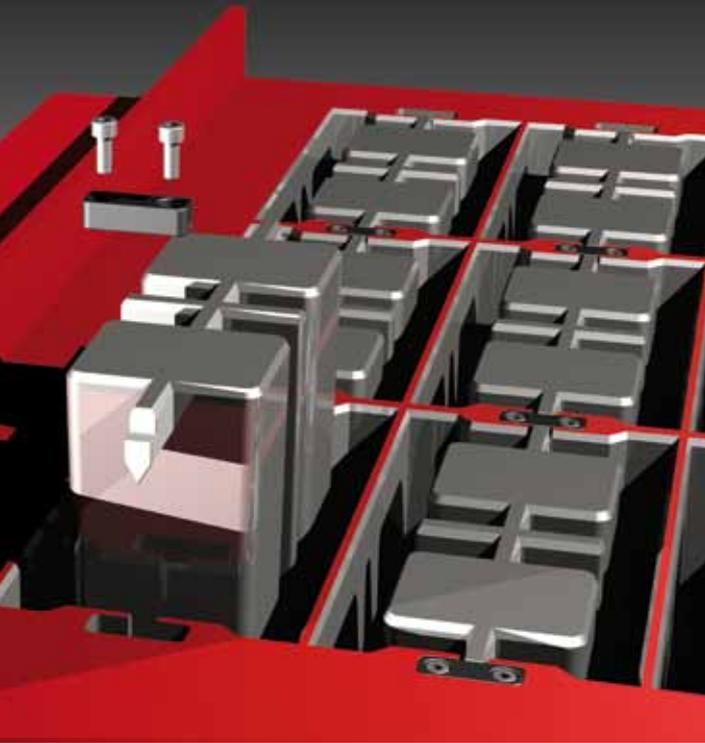

Stampi con anime  
smontabili

Moulds with  
detachable cores

Moules à âmes  
démontables

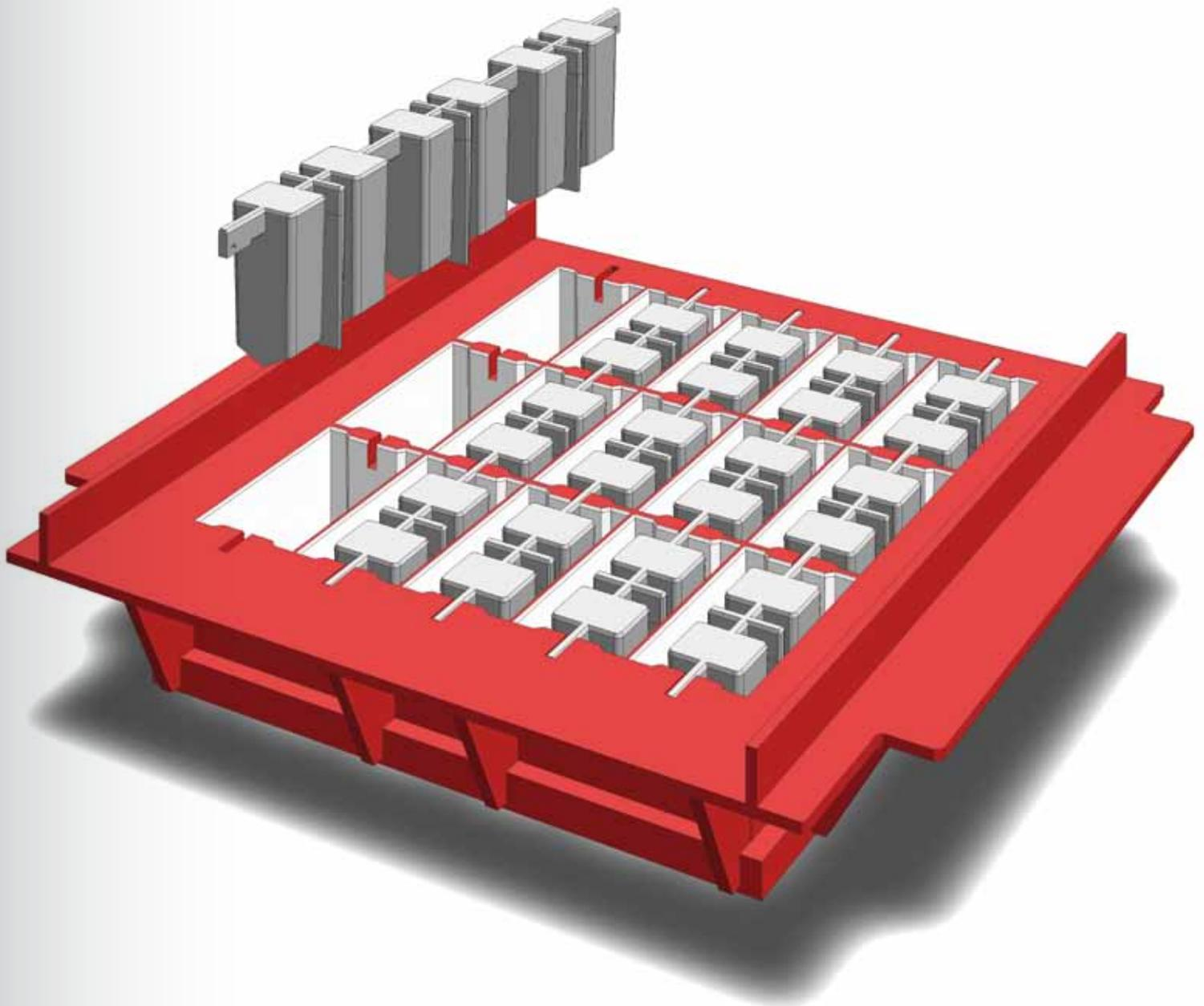



# PEGASO STAMPI

## **Pegaso Stampi S.r.l.**

Via Tevere, 1/2

53036 Poggibonsi (SI)

ITALY

Tel. +39 0577 992635

Fax +39 0577 985866

[info@pegasostampi.it](mailto:info@pegasostampi.it)

[www.pegasostampi.com](http://www.pegasostampi.com)

